

## DECK APPLICATION CHECKLIST

This list is provided only as a reference for your convenience. Not all documents listed below will be required for every project. Similarly, additional documentation may be required depending on the nature of your project.

**It is the applicant’s responsibility to submit all applicable documentation as part of their application package. Incomplete applications will not be reviewed.**

A deck permit is required when:

1. The deck is attached to a house or structure or,
2. The deck is over 2ft (24 inches) above adjacent grade or,
3. The deck is covered, regardless of the height

**Note:** Zoning approval from your local Town or Township is still required if your project does not require a building permit.

Submittal Item	Details	Documents Included with Application
<b>Application to Construct or Demolish (Form)</b>	A copy of the application form can be found on our website. <a href="#">Application to Construct or Demolish Form</a>	
<b>Schedule 1 Form</b> Include one form for each designer	A copy of the Schedule 1 form can be found on our website. <a href="#">Schedule 1 Form</a>	
<b>Agent Authorization Form</b>	Required if you are applying on behalf of a property owner. A copy of the form can be found on our website. <a href="#">Agent Authorization Form</a>	
<b>Applicable Law Declaration Form</b>	Including all approvals (i.e. NEC, Conservation, MTO, etc.) where applicable. A copy of the form can be found on our website. <a href="#">Applicable Law Declaration Form</a>	

Submittal Item	Details	Documents Included with Application
<b>Site Plan</b>	Drawn to scale including north arrow, address, distances from property lines, all existing structures, all proposed structures, septic location, etc.	
<b>Architectural Design Drawings</b>	<p><b>Construction detail examples provided below</b></p> <p>Floor plans drawn to scale including:</p> <ul style="list-style-type: none"> <li>- Footing size and location</li> <li>- Concrete pier size and location</li> <li>- Post size, location, spacing</li> <li>- Joist size, spacing, direction, span</li> <li>- Ledger board size and attachment details</li> <li>- Decking size</li> <li>- Stair layout, size, location</li> <li>- Overall dimensions of deck</li> </ul> <p>Elevations drawn to scale including:</p> <ul style="list-style-type: none"> <li>- Deck height off of grade</li> <li>- Pier depth and size</li> <li>- Footing depth and size</li> <li>- Railing/guard height and construction/attachment details</li> <li>- Railing/guard to be designed in conformance with SB-7 of the Supplementary Standards or designed by a Professional Engineer of Ontario</li> </ul>	

# DUFFERIN COUNTY

## DECK CONSTRUCTION GUIDE STANDARD RESIDENTIAL DECK DETAILS

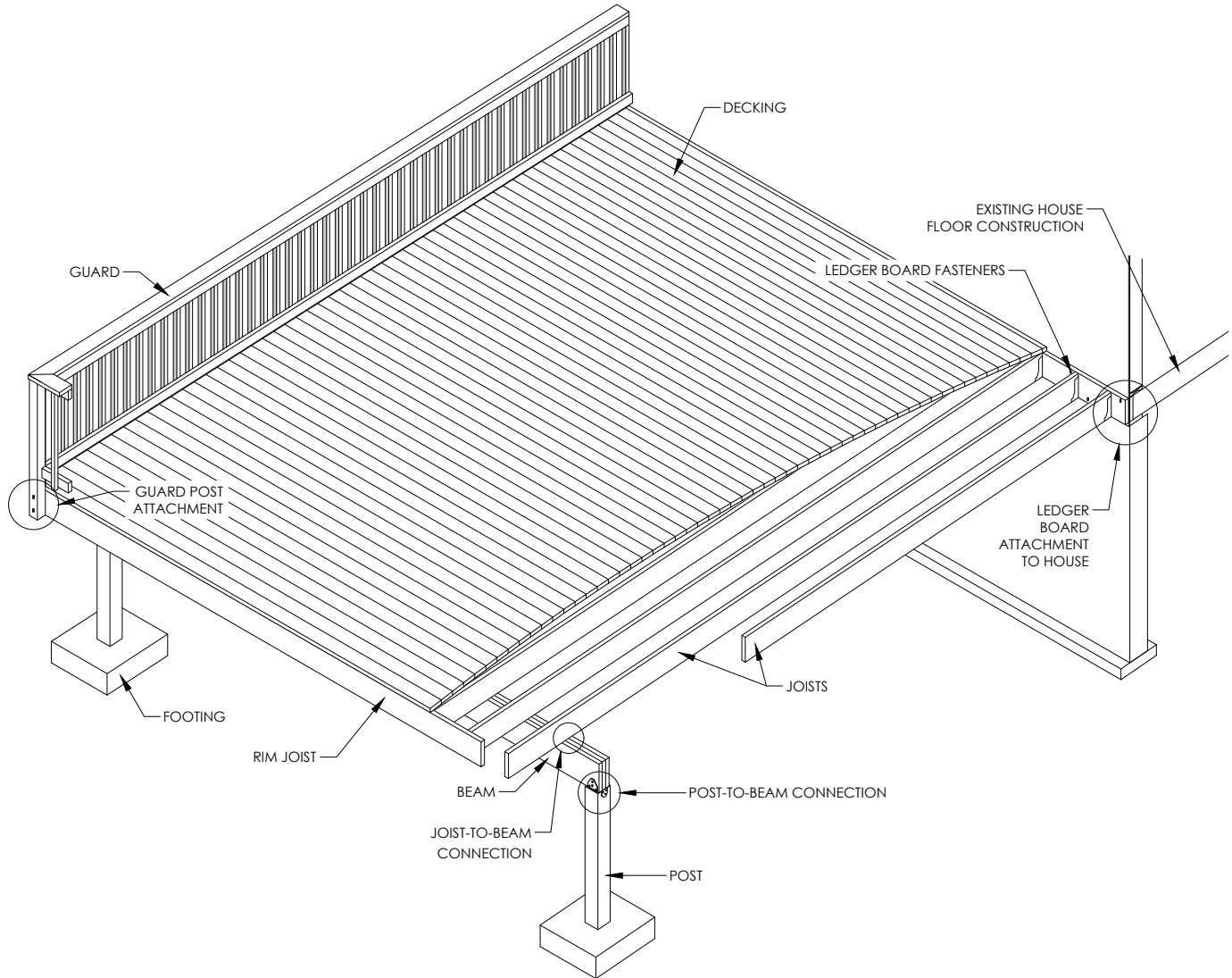

THE INFORMATION CONTAINED IN THIS DOCUMENT IS FOR REFERENCE ONLY. IT IS INTENDED TO ASSIST HOMEOWNERS WITH THEIR DECK PROJECT AND ENSURING COMPLIANCE WITH THE REQUIREMENTS OF THE ONTARIO BUILDING CODE. THE DRAWINGS AND DETAILS SPECIFIED ARE TYPICAL CONSTRUCTION DETAILS AND OTHER METHODS MAY BE PERMITTED UPON AUTHORIZATION FROM BUILDING SERVICES. ALL CONSTRUCTION SHALL BE INSPECTED INCLUDING FOOTINGS PRIOR TO PLACING CONCRETE, FRAMING AND FINAL INSPECTION PRIOR TO USE. FOR A MORE COMPLICATED DESIGN, THE ASSISTANCE OF A PROFESSIONAL DESIGNER SHOULD BE OBTAINED TO ENSURE COMPLIANCE WITH THE ONTARIO BUILDING CODE AND OTHER REGULATIONS. IT IS BEYOND THE SCOPE OF THIS DOCUMENT TO DETAIL EVERY POSSIBLE CONDITION.

ALL CONSTRUCTION SHALL CONFORM WITH THE ONTARIO BUILDING CODE.

## JOISTS, BEAMS & PIER SIZING

NOTE: SPECIFIED SNOW LOAD OF 2.0kPA IS ASSUMED FOR ALL DECKS. IF THE LIVE LOAD WILL EXCEED 2.0kPA INCLUDING HOT TUBS OR DRIFT LOADING THEN THE DECK MUST BE DESIGNED BY A PROFESSIONAL PERSON.

### BEAM SIZE - PERIMETER BEAM (JOISTS ON ONE SIDE ONLY)

JOIST SPAN	PIER SPACING (2-2x10 = 2-PLY 2"x10")				
	1.2m (4')	1.8m (6')	2.4m (8')	3.0m (10')	3.6m (12')
1.8m (6')	2-2x8	2-2x8	2-2x8	2-2X10	3-2x10
2.4m (8')	2-2x8	2-2x8	2-2x10	2-2X10	3-2x10
3.0m (10')	2-2x8	2-2x8	2-2x10	3-2X10	3-2x10
3.6m (12')	2-2x8	2-2x10	2-2x10	2-2X12	3-2x12
4.3m (14')	2-2x10	2-2x10	2-2x10	3-2X10	3-2x12

### BEAM SIZE - INTERIOR BEAM (JOISTS ON BOTH SIDES OF BEAM)

JOIST SPAN	PIER SPACING (2-2x10 = 2-PLY 2"x10"), (--- = NOT PERMITTED)				
	1.2m (4')	1.8m (6')	2.4m (8')	3.0m (10')	3.6m (12')
1.8m (6')	2-2x8	2-2x8	2-2x10	3-2X10	3-2x12
2.4m (8')	2-2x8	2-2x8	2-2x10	3-2X10	3-2x12
3.0m (10')	2-2x8	2-2x10	3-2x10	3-2X12	4-2x12
3.6m (12')	2-2x8	2-2x10	3-2x10	4-2X12	---
4.3m (14')	2-2x10	2-2x10	3-2x10	4-2X12	---

## CONSTRUCTION NOTES

### MAXIMUM JOIST SPANS

SIZE	SPACING	SPAN
2x8	12" O.C.	12'-0"
	16" O.C.	10'-0"
	24" O.C.	8'-0"
2x10	12" O.C.	14'-0"
	16" O.C.	12'-0"
	24" O.C.	10'-0"
2x12	12" O.C.	16'-0"
	16" O.C.	14'-0"

- DECKS MUST BE ATTACHED TO THE HOUSE FOUNDATION OR STRUCTURAL FRAMING (NOT BRICK VENEER) WITH MINIMUM 1/2" DIAMETER BOLTS AT A MAXIMUM 24" (600mm) ON CENTER SPACING.
- MAXIMUM CANTILEVER FOR JOISTS AND BEAMS BEYOND SUPPORTS IS 16" (405mm) FOR 2"x8" AND 24" (600mm) FOR 2"x10"
- WIDEN (BELL) BOTTOM OF PIER WHERE PIER SPACING EXCEEDS 96" (2440mm). IN COURSE GRAINED SOILS (SANDS & GRAVELS) IT MAY BE NECESSARY TO USE A 10" OR 12" AUGER, POUR A CONCRETE BASE THEN PLACE A SMALLER SONO TUBE ON TOP. DOUBLE WRAP SONO TUBE WITH POLY TO HELP PREVENT FROST HEAVING.
- FOOTINGS/PIERS SHALL BEAR ON UNDISTURBED SOIL A MINIMUM OF 48" BELOW FINISHED GRADE.
- DECK POSTS SHALL BE CENTRALLY LOCATED ON FOOTINGS/PIERS.

### LEDGER BOARD TO HOUSE ATTACHMENT - BOLT SPACING (SEE DIAGRAMS)

BOLT SIZE	JOIST SPAN			
	UP TO 1.8m (6')	2.4m (8')	3.0m (10')	3.6m (12')
1/2" (12.7mm)	812mm (32") O.C.	400mm (16") O.C.	400mm (16") O.C.	300mm (12") O.C.
EQUIVALENT 16" O.C. JOIST SPACING	EVERY OTHER JOIST SPACE	EVERY JOIST SPACE	EVERY JOIST SPACE	EACH JOIST SPACE WITH TWO EVERY OTHER SPACE
3/8" (9.5mm)	600mm (24") O.C.	300mm (12") O.C.	300mm (12") O.C.	200mm (8") O.C.
EQUIVALENT 16" O.C. JOIST SPACING	TWO EVERY 3RD JOIST SPACE	EACH JOIST SPACE WITH 2 EVERY OTHER SPACE	EACH JOIST SPACE WITH 2 EVERY OTHER SPACE	TWO EACH JOIST SPACE WITH THREE EVERY OTHER SPACE

## LEDGER BOARD ATTACHMENT NOTES

- DECKS ARE USUALLY SUPPORTED ON ONE SIDE BY A LEDGER BOARD ATTACHED TO THE HOUSE. THIS LEDGER ATTACHMENT IS CRITICAL TO ENSURE THE DECK IS SAFELY AND SECURELY SUPPORTED AT THE HOUSE. THERE ARE VERY SPECIFIC REQUIREMENTS THAT MUST BE MET. FOLLOW THE DIAGRAMS CLOSELY FOR THE PROPER ATTACHMENT OF THE LEDGER.
- THE DECK LEDGER SHALL **NOT** BE NAILED TO THE HOUSE. IT MUST BE LAGGED SCREWED OR BOLTED TO THE STRUCTURE OF THE HOUSE.
- THE SIZE AND SPACING OF THE FASTENERS IS BASED ON THEIR CAPACITY. LAG SCREW VALUES ARE ASSUMED TO BE 325 POUNDS FOR 1/2" LAG SCREWS/BOLTS AND 190 POUNDS FOR 3/8" LAG SCREWS/BOLTS. THE SPAN OF THE FLOOR JOISTS DETERMINES HOW MUCH LOAD IS BEING TRANSFERRED TO THE LEDGER AND THUS TO THE LAG SCREWS.
- DECK LEDGERS SHALL BE A MINIMUM OF 2x8 PRESSURE TREATED No. 2 GRADE (OR BETTER) LUMBER OR OTHER APPROVED MATERIALS AS DETERMINED BY GOOD ENGINEERING PRACTICES.
- WHEN SOLID SAWN PRESSURE TREATED DECK LEDGERS ARE ATTACHED TO ENGINEERED WOOD PRODUCTS (STRUCTURAL COMPOSITE LUMBER RIM BOARD OR LAMINATED VENEER LUMBER), THE LEDGER BOARD ATTACHMENT SHALL BE DESIGNED IN ACCORDANCE WITH THE MANUFACTURER'S RECOMMENDATIONS OR GOOD ENGINEERING PRACTICES.
- PILOT HOLES SHALL BE PRE-DRILLED WITH A SIZE BETWEEN 17/32" TO 9/16".
- LAG SCREWS ARE ONLY PERMITTED WHERE EXISTING SITE CONDITIONS CAN BE CONFIRMED.

### DECK SUPPORTS: POST SIZING

POST SIZE	MAXIMUM HEIGHT	AREA m <sup>2</sup> (ft <sup>2</sup> )
89mm x 89mm (4" x 4")	1.0m (3'-3")	8.09 (87)
	1.5m (5'-0")	4.42 (48)
	2.0m (6'-7")	2.35 (25.3)
140mm x 140mm (6" x 6")	2.0m (6'-7")	10.2 (110)
	2.5m (8'-2")	6.95 (74.8)
	3.0m (10'-0")	4.74 (51)
	3.5m (11'-6")	3.29 (35.4)

### CONCRETE PIER SIZE (DIAMETER IN mm & (INCHES))

JOIST SPAN	PIER SPACING			
	1.2m (4')	1.8m (6')	2.4m (8')	3.0m (10')
1.8m (6')	200 (8")	250 (10")	300 (12")	350 (14")
2.4m (8')	250 (10")	300 (12")	350 (14")	400 (16")
3.0m (10')	300 (12")	350 (14")	400 (16")	460 (18")
3.6m (12')	300 (12")	350 (14")	400 (16")	460 (18")

- TRIBUTARY LOAD: SUPPORTED DECK AREA
- DECK SUPPORTING HOT TUBS MUST BE DESIGNED BY A QUALIFIED PERSON

TITLE:



# WOOD DECK

# D02

PLANS, CONNECTION DETAILS & SPECIFICATIONS

## JOIST TO BEAM CONNECTION DETAILS

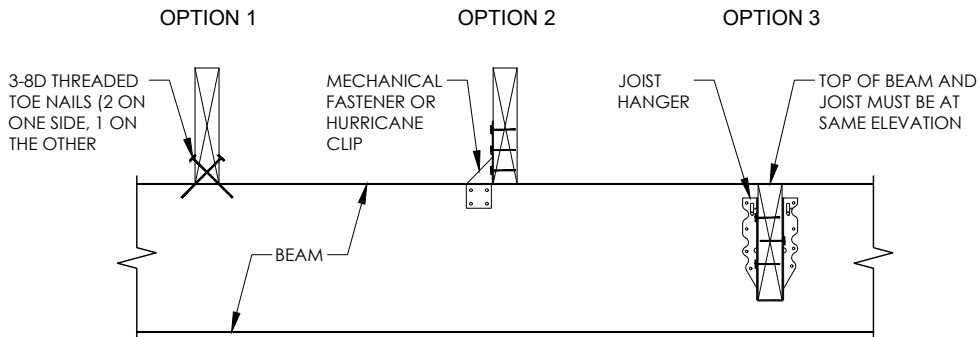

## POST TO BEAM - STEEL POST CAP CONNECTION DETAILS

3-PLY BEAMS MUST USE POST CAP OPTION

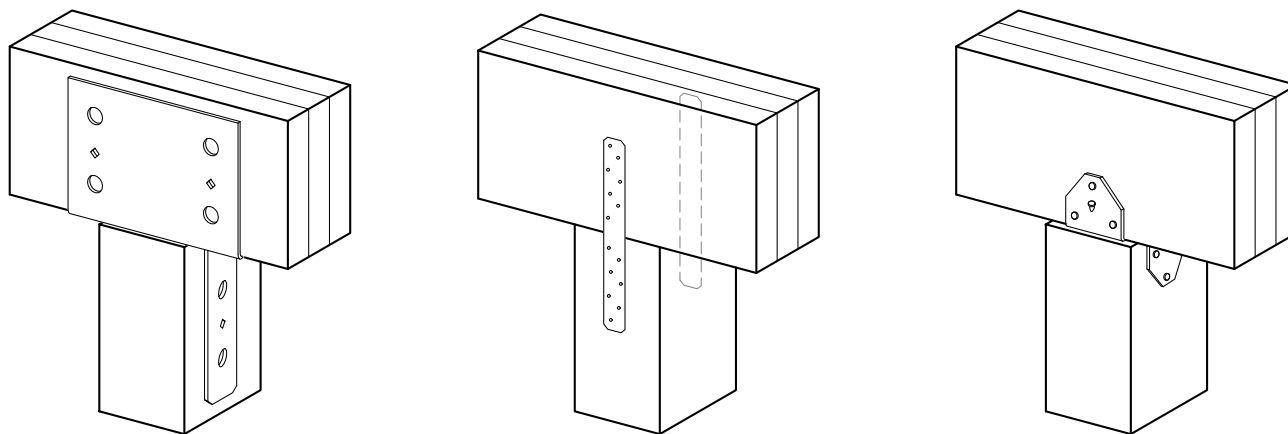

## POST TO BEAM - WOOD TO WOOD CONNECTION DETAILS

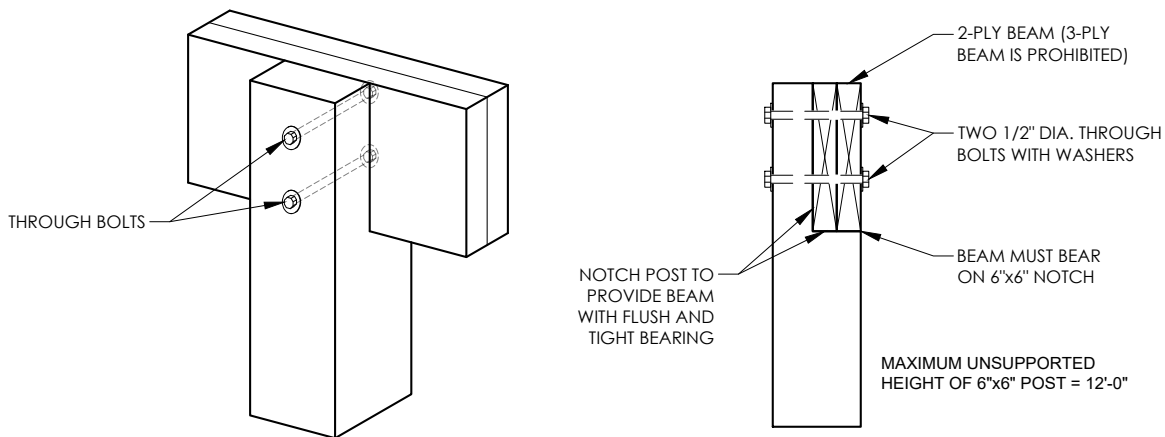

## LEDGER BOARD FASTENER SPACING

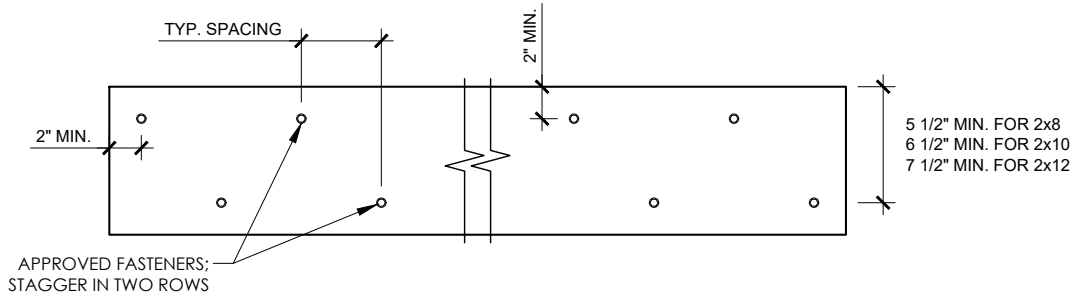

## LEDGER CONNECTION TO RIM BOARD

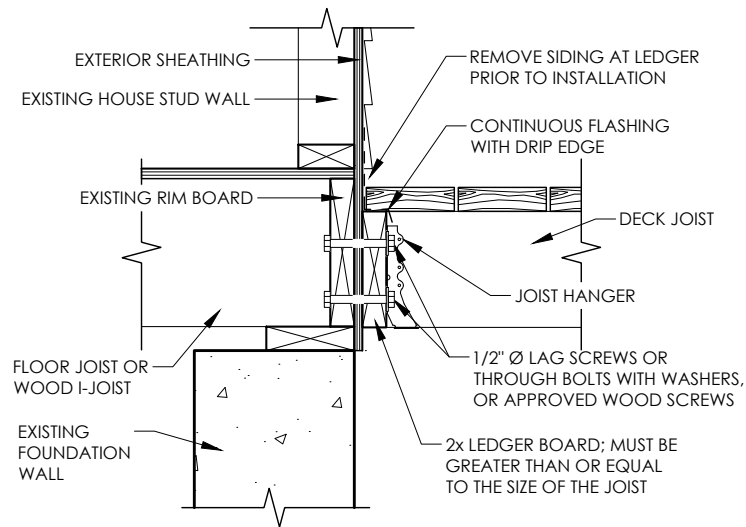

## LEDGER CONNECTION TO POURED CONCRETE FOUNDATION WALL

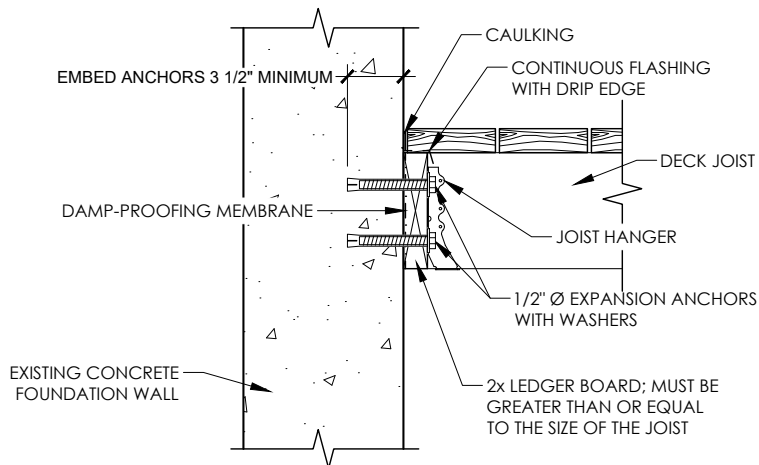

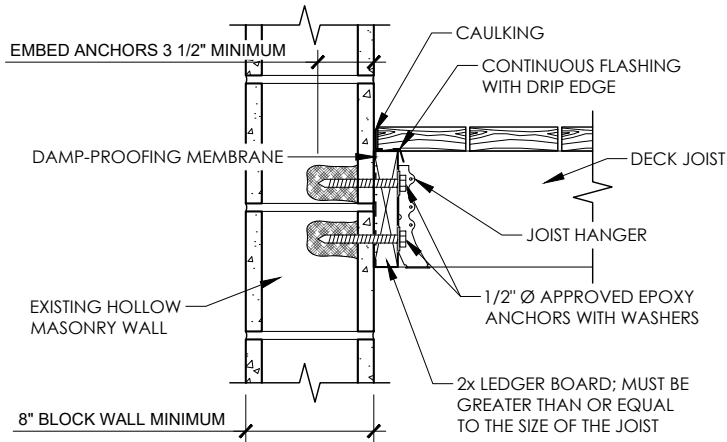

**WALL CONNECTION TO BLOCK WALL**

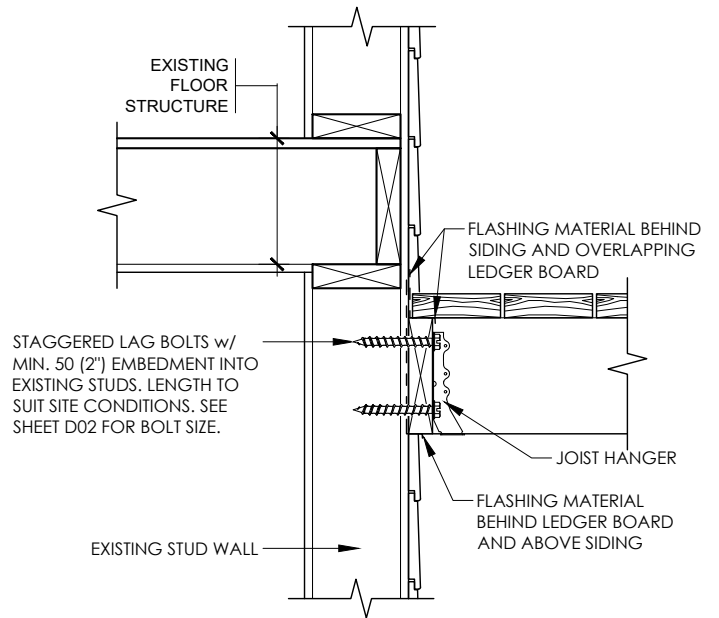

**WALL CONNECTION TO WOOD STUDS**

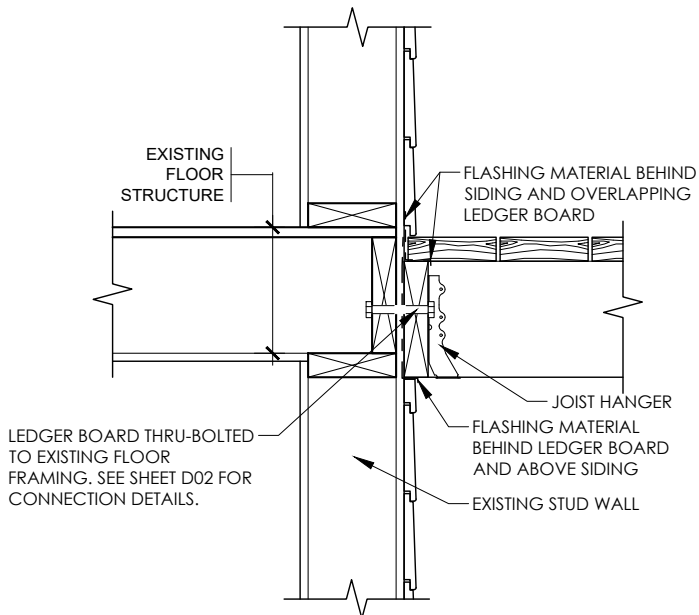

**WALL CONNECTION THROUGH SIDING WALL**

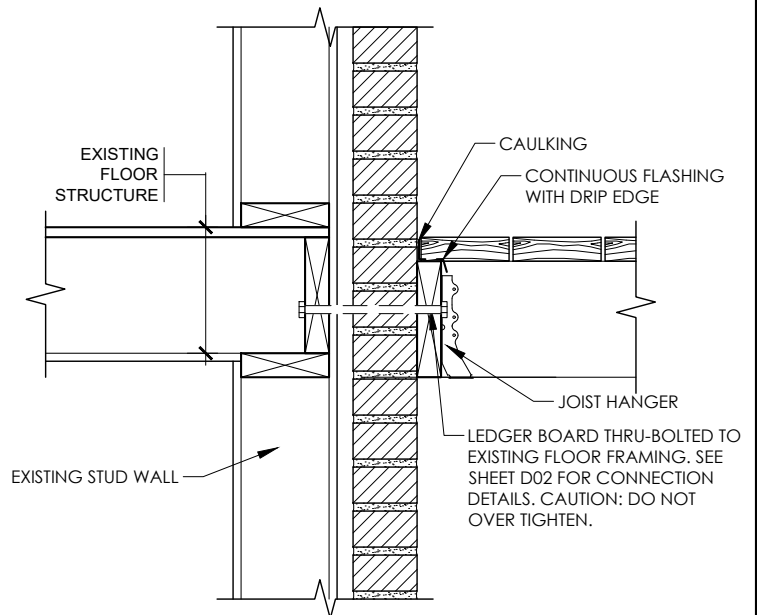

**WALL CONNECTION THROUGH BRICK WALL**

## DECK FRAMING AROUND CHIMNEY OR BAY WINDOW

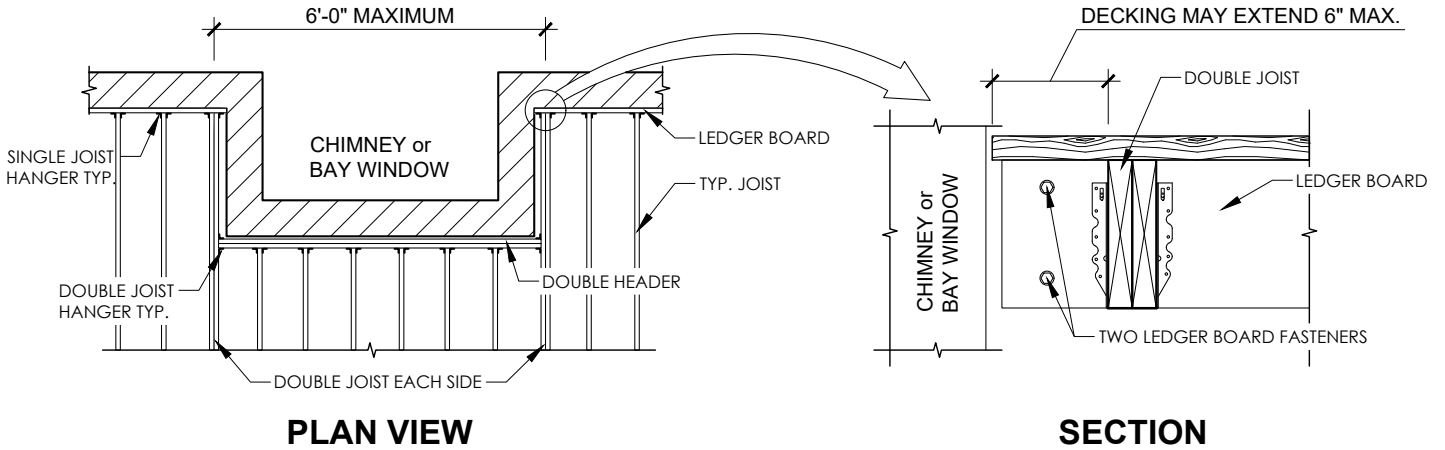

## TRIBUTARY LOAD AREA FOR POSTS

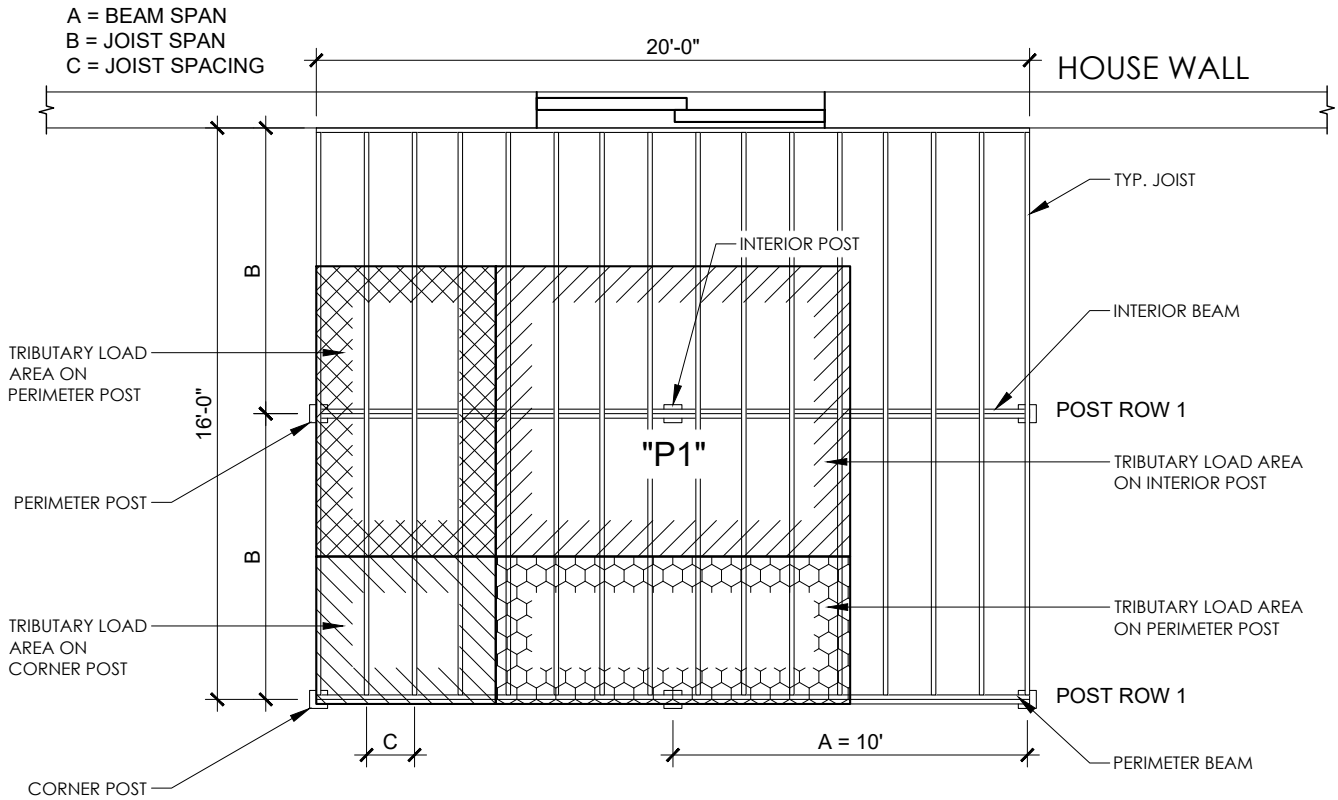

EXAMPLE FOR LOADING ON "P1":

**TRIBUTARY AREA**  

$$= [(8/2) + (8/2)] \times [(10/2) + (10/2)]$$

$$= [(4 + 4) \times (5 + 5)]$$

$$= 8 \times 10$$

$$= 80 \text{ ft}^2$$

FROM THE TABLE; A 6 x 6 POST WITH A MAXIMUM HEIGHT OF 12' IS PERMITTED



# STAIR AND GUARD CONSTRUCTION DETAIL

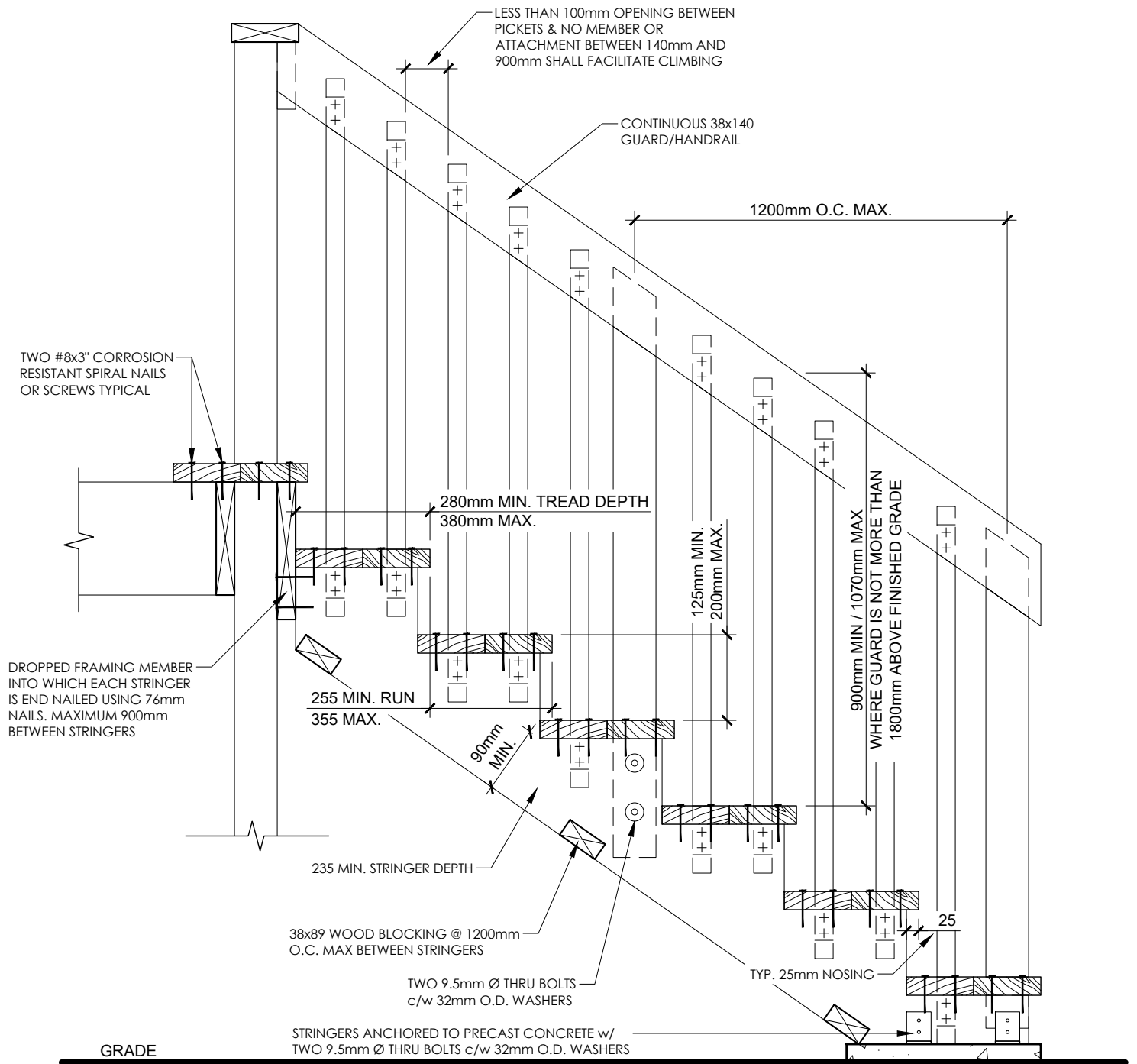

## DETAIL ED-1 of SB-7 GUIDE

EXTERIOR CONNECTION: CANTILEVERED PICKET SCREWED TO RIM JOIST

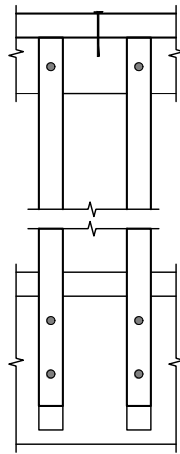

**FRONT ELEVATION**

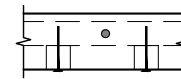

**PLAN VIEW**

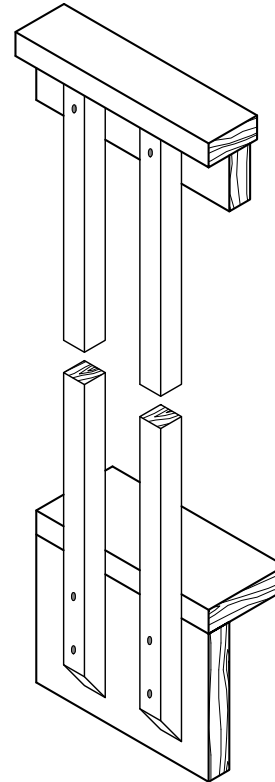

**AXONOMETRIC**

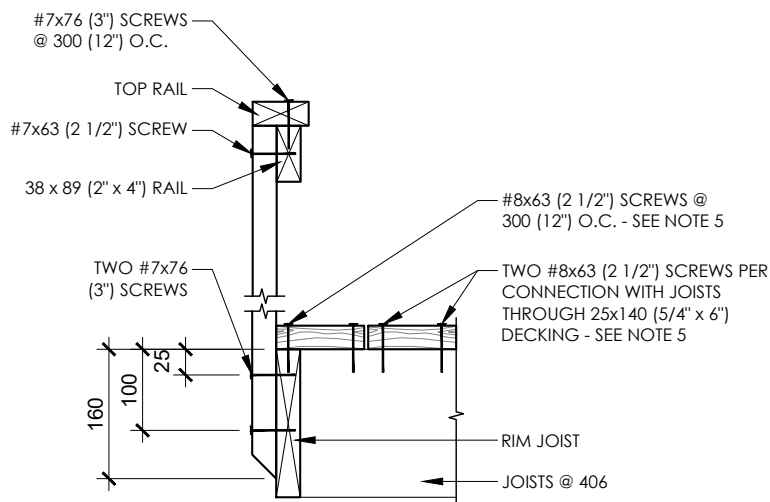

**SECTION**

**NOTES:**

1. PROVIDE A SUITABLE POST, RETURN, OR SOLID SUPPORT AT EACH END OF GUARD
2. WOOD FOR CANTILEVERED PICKETS SHALL BE DOUGLAS FIR-LARCH, SPRUCE-PINE-FIR, or HEM-FIR SPECIES
3. FASTEN RIM JOIST TO EACH FLOOR JOIST WITH THREE 82 (3 1/4") NAILS
4. DIMENSIONS SHOWN ARE IN mm UNLESS OTHERWISE NOTED
5. THE OUTER DECK BOARD SHALL BE NOT LESS THAN 140 (6") WIDE. WHERE 38 (2" NOMINAL) THICK BOARDS ARE USED, THE LENGTH OF THE WOOD SCREWS SHALL BE NOT LESS THAN 76 (3")

**DETAIL EB-1 of SB-7 GUIDE**  
EXTERIOR CONNECTION: POST NAILED TO RIM JOIST

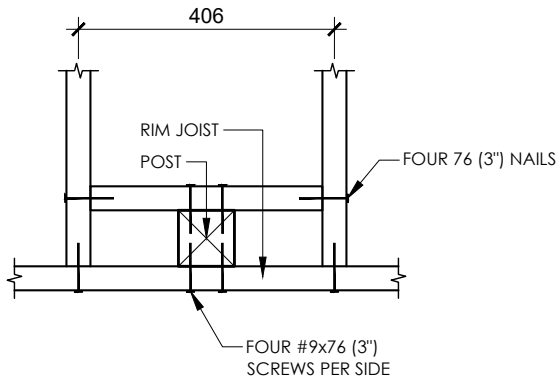

**PLAN VIEW**

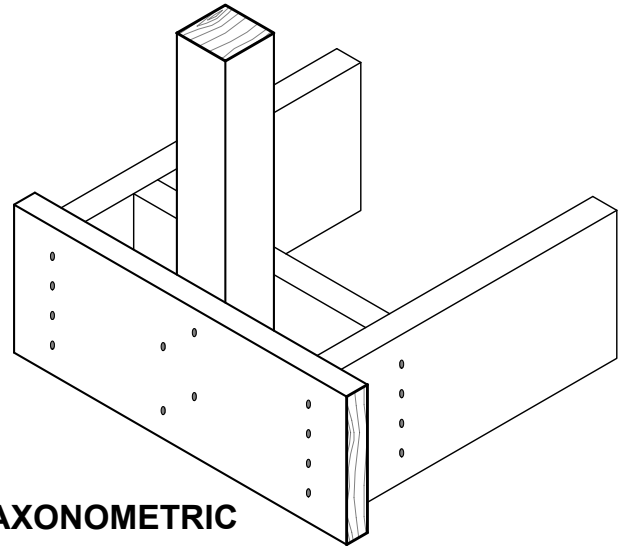

**AXONOMETRIC**

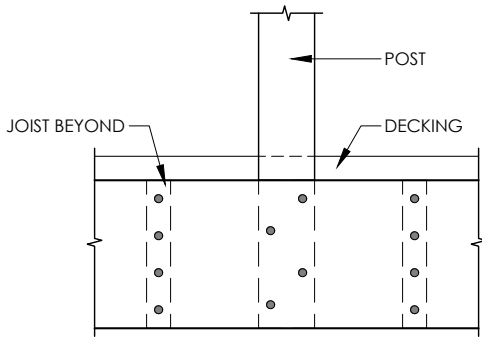

**FRONT ELEVATION**

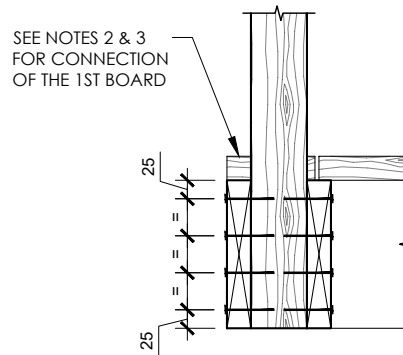

**SECTION**

**NOTES:**

1. DECKING IS OMITTED FROM THE PLAN VIEW AND AXONOMETRIC VIEW FOR CLARITY.
2. FASTEN 25x140 (5/4"x6") OUTER DECK BOARD TO RIM JOIST WITH 63 (2 1/2") NAILS @ 300 (12").
3. FASTEN 25x140 (5/4"x6") OUTER DECK BOARD TO FLOOR JOIST WITH ONE 63 (2 1/2") NAIL AT EACH JOIST.
4. THE POST MAY BE POSITIONED ANYWHERE BETWEEN JOISTS.
5. DIMENSIONS ARE IN mm UNLESS OTHERWISE SPECIFIED.

MAXIMUM SPAN OF RAIL BETWEEN POSTS	
SPECIES	MAXIMUM SPAN, m (ft - in)
DOUGLAS FIR-LARCH, HEM-FIR, SPRUCE PINE FIR	1.22 (4'-0")
NORTHERN SPECIES	1.20 (3'-11")

## BRACING SUPPORT

### BRACING PARALLEL TO BEAM

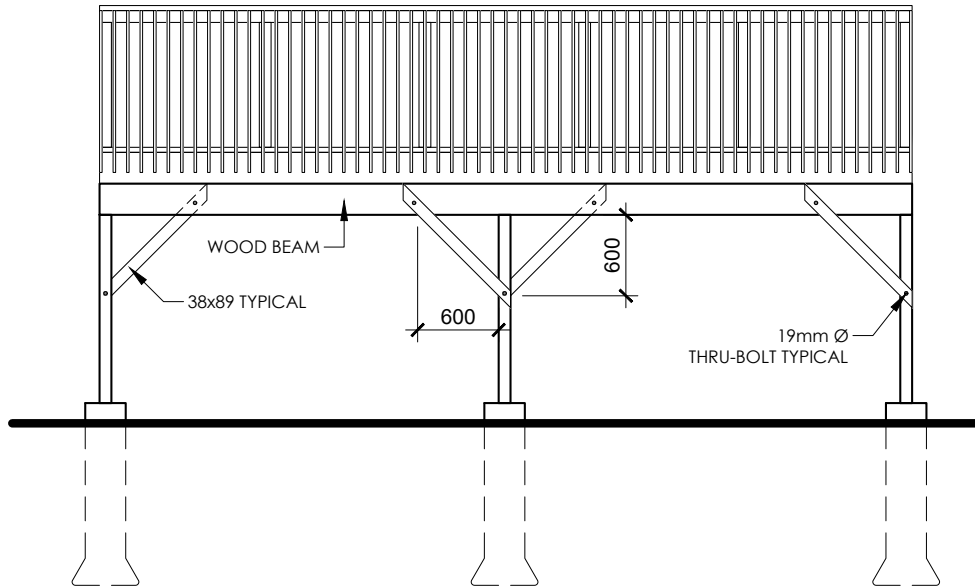

### BRACING PERPENDICULAR TO BEAM

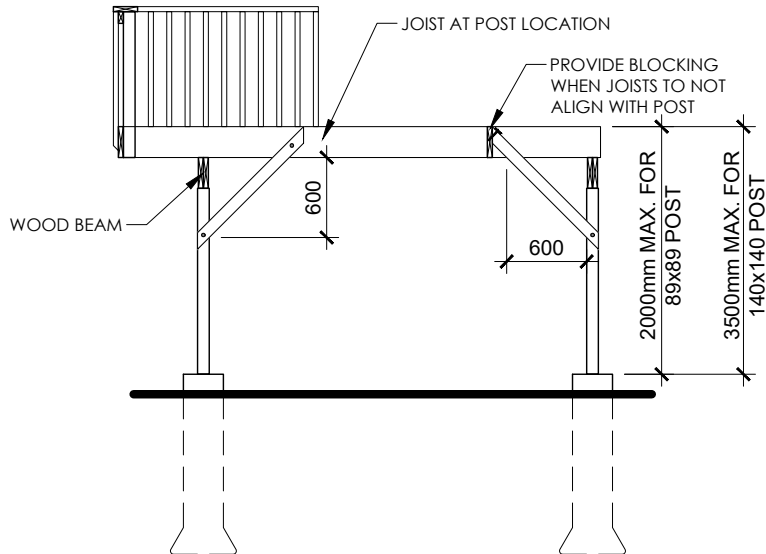

FREE STANDING DECKS GREATER THAN 600mm ABOVE GRADE SHALL RESIST LATERAL LOADING AND MOVEMENT. ALL POSTS MUST BE BRACED WHERE THE DECK WALKING SURFACE TO FINISHED GRADE EXCEEDS 1.5m (5').

#### NOTES:

1. LUMBER No. 2 SPF or BETTER WOOD POSTS, MINIMUM 89x89 (4"x4") SOLID. USE CORROSION RESISTANT SPIRAL NAILS or SCREWS.
2. DECK IS NOT PERMITTED TO BE SUPPORTED ON BRICK VENEER.
3. CONCRETE PIERS SHALL BEAR ON UNDISTURBED SOIL OR BEDROCK. THE BEARING CAPACITY OF THE SOIL SHALL BE DETERMINED PRIOR TO CONSTRUCTION.
4. PROVIDE A HANDRAIL 900mm HIGH ON STAIRS IF MORE THAN THREE RISERS.
5. MAXIMUM HEIGHT REFERS TO THE HEIGHT OF THE POST FROM THE TOP OF THE PIER TO THE DECK SURFACE.
6. DIMENSIONS ARE IN mm UNLESS OTHERWISE SPECIFIED.
7. ALL DECK GUARDS SHALL BE 42" (1070mm) HIGH FOR DECK SURFACES 5'-11" (1800mm) OR MORE ABOVE FINISHED GRADE.
8. DECKS LESS THAN 5'-11" (1800mm) ABOVE FINISHED GRADE REQUIRE A 36" (915mm) HIGH GUARD.
9. GUARDS SHALL NOT BE CLIMBABLE.

# DECK SECTION DIAGRAM

